

LOUNGE

TABLES

**Price Guide** ◀





# TABLE OF CONTENTS

---

3	General Information
5	Product Specifications
7	Pricing - Lounge Tables

## General Information

---

Sales of In2design products are in accordance with the terms and conditions outlined in this Price List. These terms and conditions may be changed or supplemented only by a separately written document signed and authorized by in2design.

### Prices

The prices published in this Price List, as well as those quoted by in2design shall be suggested List Prices. List Prices are subject to change without prior notice.

List Prices are those that are in effect at time of order receipt. If shipping date requested is more than 90 days from date of order, in2design shall have the right to use the published list prices effective at the time of shipment.

### Taxes

All prices shown in this Price List are exclusive of sales, excise, GST and other applicable taxes. The Purchaser is responsible to remit directly to in2design all such taxes as per the invoice.

A Tax Exemption Certificate (if applicable) must be on file with in2design prior to the product shipment, otherwise, sales tax will be due and payable.

### Payment Terms

All orders are invoiced at time of shipment. Terms of payment are NET thirty (30) days from date of invoice.

In2design shall exercise the right to enforce a charge amounting to 2% per month, or 24% annually on any past due invoice or outstanding balance.

All products sold shall remain the personal property of in2design until fully paid. The purchaser agrees to perform all acts which may be necessary to assure retention of title to such products to in2design until such time as the products have been paid in full.

### Credit

Should the Purchaser fail to fulfill the terms of payment, in2design may defer further shipments until all such payments are made or may, at its option cancel the unshipped balance without prejudice to any other rights which in2design may have against the Purchaser.

Shipments and deliveries shall at all times be subject to approval of the Purchaser's credit.

### Order Placement

In2design requires that all orders be submitted in writing as represented by a valid Purchase Order and accompanied by a layout/drawing to avoid errors and or duplication. The Purchaser is responsible for providing complete and accurate information when placing an order. Orders with incorrect/incomplete information will result in order processing and shipment delays. Product leadtimes will be based upon receipt of a complete and accurate Purchase Order.

### Order Acknowledgement

All orders submitted will be acknowledged. It is the Purchaser's responsibility to review the acknowledgement for accuracy. In the event of an error, the Purchaser must notify in2design immediately (within 48 hours) in writing by fax or e-mail.

### Delivery Dates

In2design shall exercise its best efforts to deliver within the date specified on the Acknowledgement. In2design shall not incur any obligation or liability to the Purchaser for delay or failure to deliver goods due to causes beyond our control.

### Order Changes & Cancellations

Any changes to the original Purchase Order must be received in writing within 48 hrs of the order acknowledgement. Any change to the original Purchase Order beyond the 48 hrs will result in re-scheduling and subject to a restocking charge commensurate with the incurred production costs.

All orders are considered firm and not subject to cancellation by the Purchaser without the written consent of in2design. Special order items and COM items are not subject to changes or cancellation under any circumstances.

### COM Orders

A request for non-standard material (laminates) must be approved prior to acceptance of an order. Material must be shipped prepaid to in2design Customer Service Team and properly identified. Performance of COM is the sole responsibility of the Purchaser.

### Errors & Omissions

All quotations, acknowledgements and invoices are subject to corrections for any errors and omissions.

### **Shipping & Delivery**

All products are sold F.O.B. in2design's Manufacturing Facility: Vaughan Ontario, unless otherwise stated and agreed.

The Purchaser will determine the method of transportation and the routing of shipment.

### **Shipping & Delivery**

All deliveries will be dock-to-dock, unless otherwise specified.

### **Shipment Claims**

In2design carefully prepares and inspects all products for safe shipment. Legal title to merchandise passes to the Purchaser upon acceptance by the carrier. Inspect all cartons upon delivery.

It is the responsibility of the Purchaser to examine goods upon receipt and to file any claims with the carrier for losses or damage to the product. Details of visible damage should be noted on the delivery receipt. Product shortages must be noted on delivery receipts at the time of delivery and immediately reported to the carrier for correction.

Failure to make any claims against in2design within 10 days shall constitute acceptance of the products and a waiver of any defects, errors or shortages discovered upon inspection.

### **Product Returns**

No return of product will be accepted without the written consent of in2design. Any shipment returned without prior written approval will be refused and returned to the sender freight collect. If approved, a minimum restocking charge of 35% of the original net price shall be charged on returns for credit or refund provided the goods are received in original factory condition.

### **Storage**

In the event the Purchaser requests postponement of the shipment beyond the scheduled delivery date, in2design, in2design may transfer product to storage at the Purchaser's risk and expense. Upon such transfer, the Purchaser assumes risk of loss or damage.

### **Product Warranty**

In2design warrants its products to be free from defects in material and workmanship for a period of ten (10) years from the date of delivery. This warranty extends only to original Purchasers acquiring the product directly from Authorized Dealers and shall apply to product(s) installed by Authorized installers.

This warranty does not extend to C.O.M. applied to in2design products, or products which have been modified or installed contrary to recommended application and installation guidelines.

In2design will not authorize any warranty, parts or labour without the appropriate warranty numbers. All claims with respect to products alleged to be defective must be made within ten (10) days and submitted in writing.

This warranty excludes normal wear and tear, damages caused during shipment or storage; damage due to accident; improper use, negligence or willful abuse; unauthorized alternations or improper installation.

In2design extends no other warranties, expressed or implied, including warranty of merchantability or fitness for a particular purpose. In2design shall not be liable for loss of time, inconvenience, commercial loss, incidental or consequential damages.

### **Customer Satisfaction**

Our goal is to provide the very best service to our customers and to ensure complete product and performance satisfaction. We will exercise our best efforts to achieve this goal.

### **Quality Standards**

All in2design products are ANSI/BIFMA tested and manufactured to ISO 9001 Quality Standards.

# Product Specifications

---

## Lounge Tables

Tables are available in a vast selection of High Pressure Laminates (HPL), Brite White (BW) & White Colorcore (CC).

Two “styles” are offered with 1.5” & 3” thick frames. All Frame Edges are seamlessly finished with matching 1mm thick PVC edgebanding or self-edge providing durability & user safety.

Our offering includes Desk (30”) & Bar heights (42”). Tables are available in various widths and depths. Tables are comprised of a Top, Support Panels, Support Rails, Integrated Wire Management System & Power Centres on Powered units.

## Power Centres

Contemporary style power solution, constructed of durable die-cast zinc finished in Metallic Silver powder coat. Standard with 2 simplexes, one touch accessibility, UL Listed. Tables 8’ & 10’ in length include 2 Power Centres, 1 with a 6 Ft. 15 Amp cord & 1 with 120” cord. In addition 8’ & 10’ tables include a 6 outlet Power Strip with surge protection.

## Wire Management

The Lounge Tables feature integrated wire management channels to facilitate cables from core drill or wall outlets. For additional details please refer to specification drawings.

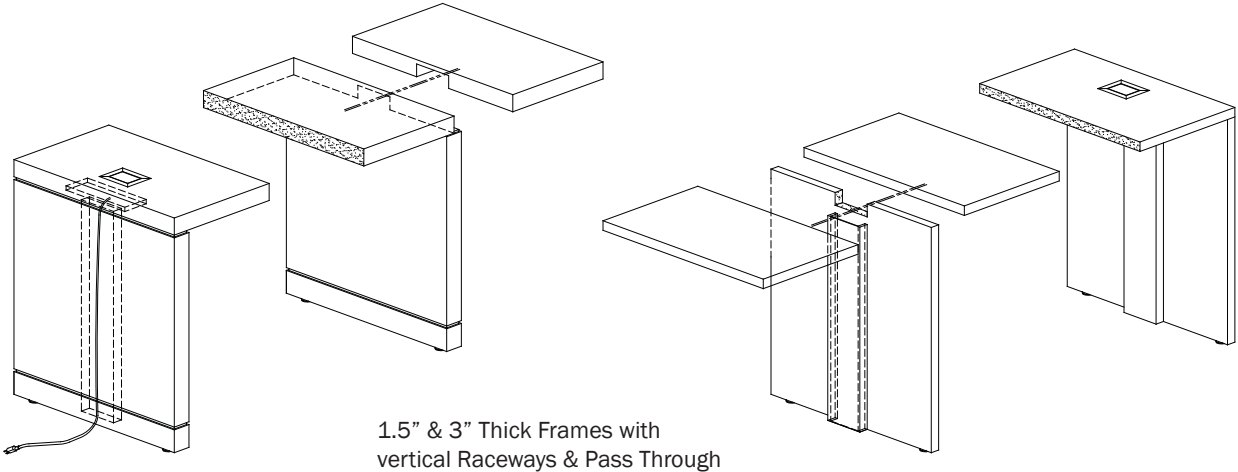

## Connections

Metal-to-Metal mini-fix and Dowel Joinery connections. All hardware is included. Each Module is shipped ready to be assembled.

## Adjustable Glides

Each Support Panel is equipped with four (4) 1-5/8” diameter Heavy Duty adjustable glides.

## Woodgrain Direction

Standard Woodgrain Direction for Support Panels & Wire Managers is “vertical”, direction for Tops & Support Rails is horizontal (long grain).

## Finish Options

Please consult with your In2design Representative.

## Product Codes

Product codes contained herein identify the product category, product size and product attributes. Laminate finish selections are required to complete the product code.

Lounge Tables - Product Overview

1.5" Thick Frames

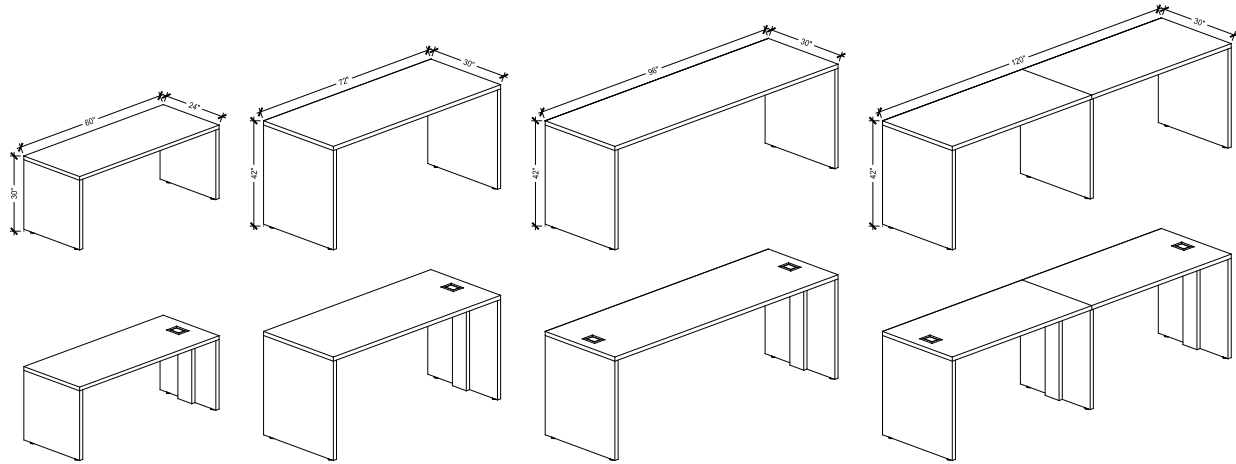

3" Thick Frames

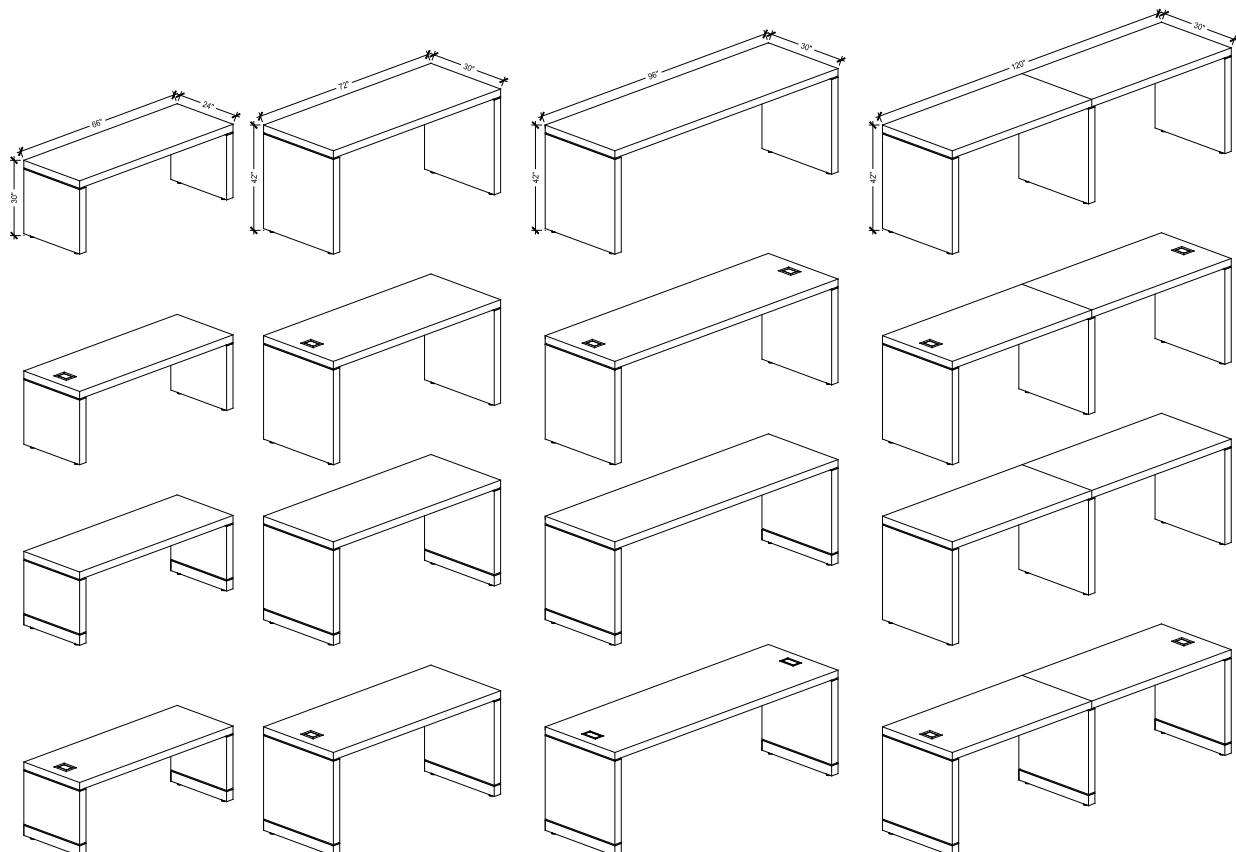

## Lounge Tables (1.5" Thick)

Description	Product Code	HPL Price	BW Price	Dimensions			Weight	Cubic Feet
				W	D	H		

### 60" x 24" Desk Height

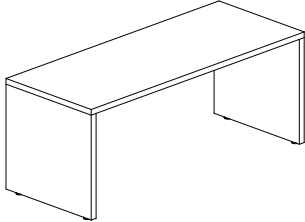

LT 602430	2365	2495	60	24	30	189	5.6
-----------	------	------	----	----	----	-----	-----

### 72" x 30" Bar Height

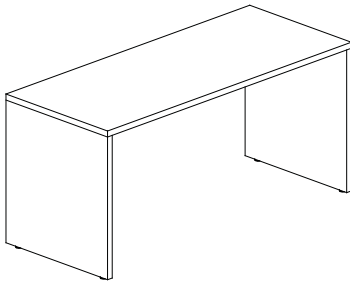

LT 723042	3015	3185	72	30	42	282	8.3
-----------	------	------	----	----	----	-----	-----

### 96" x 30" Bar Height

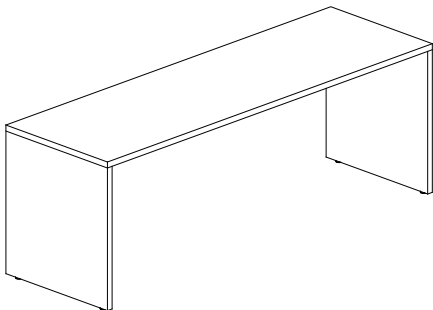

LT 963042	3450	3645	96	30	42	340	11
-----------	------	------	----	----	----	-----	----

### 120" x 30" Bar Height

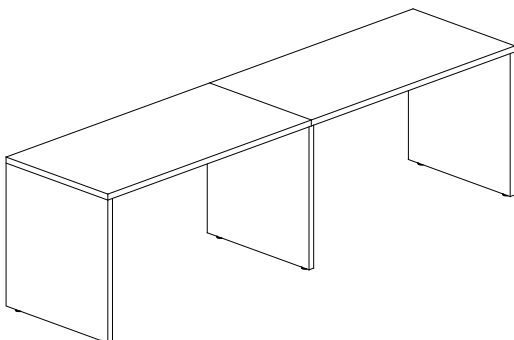

LT 1203042	4320	4565	120	30	42	388	11.5
------------	------	------	-----	----	----	-----	------



## Lounge Tables (1.5" Thick)

Description	Product Code	HPL Price	BW Price	Dimensions			Weight	Cubic Feet
				W	D	H		

### 60" x 24" Desk Height with Power

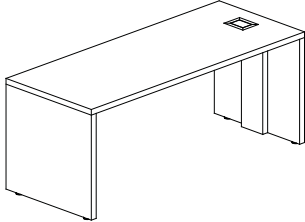

LT 602430 P	2775	2915	60	24	30	199	7.5
-------------	------	------	----	----	----	-----	-----

### 72" x 30" Bar Height with Power

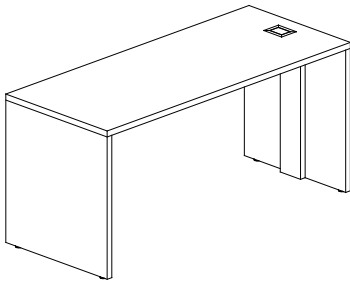

LT 723042 P	3440	3620	72	30	42	295	11
-------------	------	------	----	----	----	-----	----

### 96" x 30" Bar Height with Power

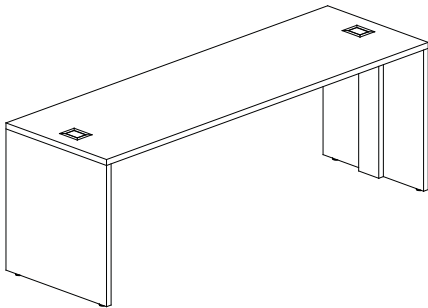

LT 963042 P2	4400	4610	96	30	42	366	14.6
--------------	------	------	----	----	----	-----	------

### 120" x 30" Bar Height with Power

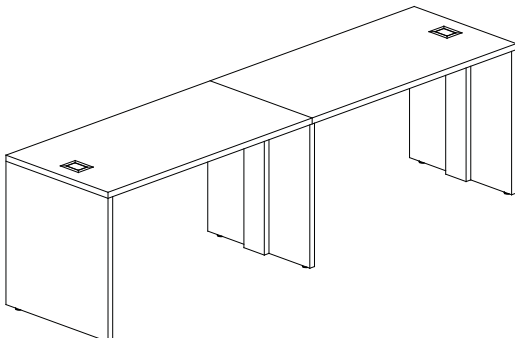

LT 1203042 P2	5445	5720	120	30	42	415	13.8
---------------	------	------	-----	----	----	-----	------

## Lounge Tables (3" Thick)

Description	Product Code	HPL Price	CC Price	Dimensions			Weight	Cubic Feet
				W	D	H		

### 66" x 24" Desk Height

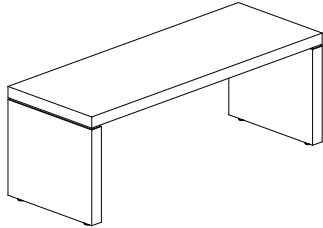

LT3 662430	3285	3615	66	24	30	204	10.3
------------	------	------	----	----	----	-----	------

### 72" x 30" Bar Height

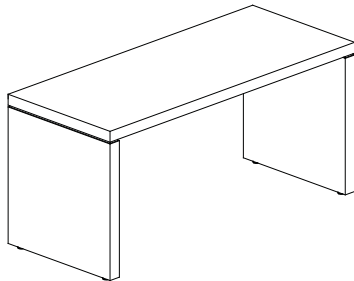

LT3 723042	3725	4215	72	30	42	296	13.7
------------	------	------	----	----	----	-----	------

### 96" x 30" Bar Height

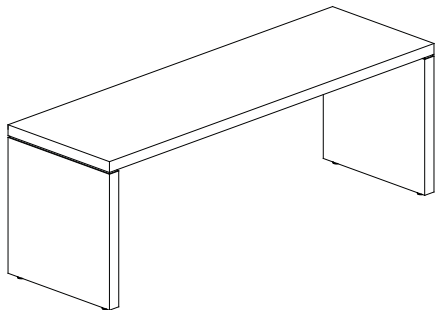

LT3 963042	4485	5110	96	30	42	357	18.2
------------	------	------	----	----	----	-----	------

### 120" x 30" Bar Height

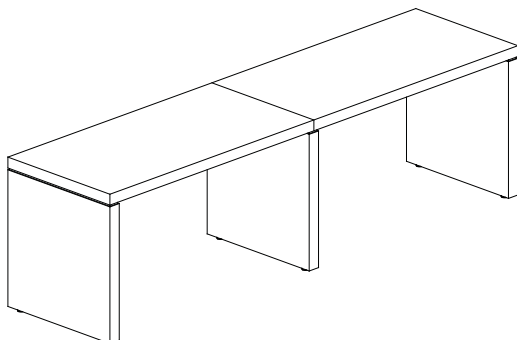

LT3 1203042	5735	6525	120	30	42	464	15
-------------	------	------	-----	----	----	-----	----

## Lounge Tables (3" Thick)

Description	Product Code	HPL Price	CC Price	Dimensions W x D x H	Weight	Cubic Feet
-------------	--------------	-----------	----------	-------------------------	--------	---------------

### 66" x 24" Desk Height with Power

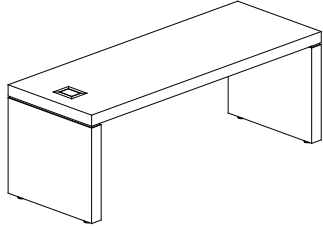

LT3 662430 P	3540	3870	66 24 30	206	10.3
--------------	------	------	----------	-----	------

### 72" x 30" Bar Height with Power

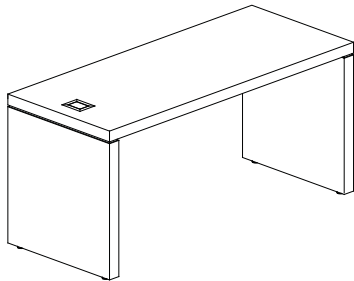

LT3 723042 P	3980	4470	72 30 42	298	13.7
--------------	------	------	----------	-----	------

### 96" x 30" Bar Height with Power

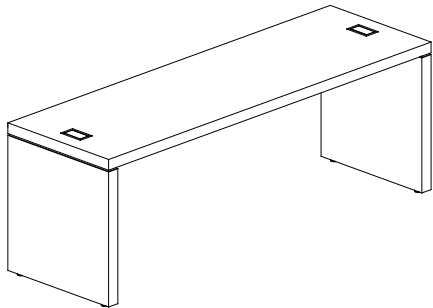

LT3 963042 P2	5085	5710	96 30 42	362	18.2
---------------	------	------	----------	-----	------

### 120" x 30" Bar Height with Power

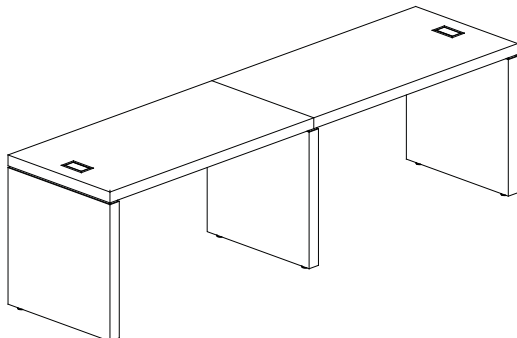

LT3 1203042 P2	6335	7125	120 30 42	468	15
----------------	------	------	-----------	-----	----

## Lounge Tables (3" Thick) with DecoMetal Brushed Aluminum Base

Description	Product Code	HPL Price	CC Price	Dimensions			Weight	Cubic Feet
				W	D	H		

### 66" x 24" Desk Height

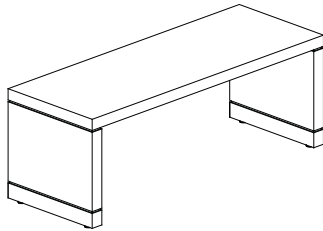

LT3B 662430	3640	3920	66	24	30	206	10.3
-------------	------	------	----	----	----	-----	------

### 72" x 30" Bar Height

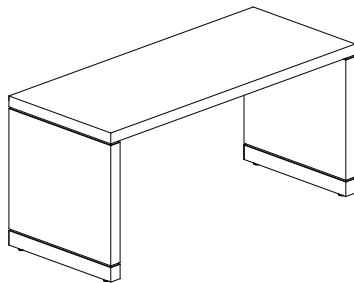

LT3B 723042	4105	4550	72	30	42	298	13.7
-------------	------	------	----	----	----	-----	------

### 96" x 30" Bar Height

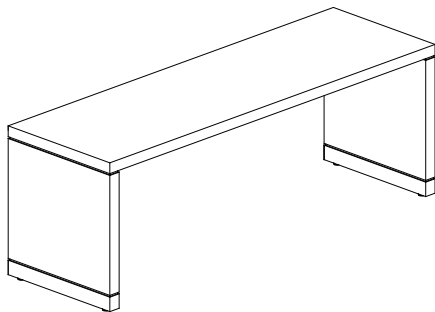

LT3B 963042	4865	5445	96	30	42	359	18.2
-------------	------	------	----	----	----	-----	------

### 120" x 30" Bar Height

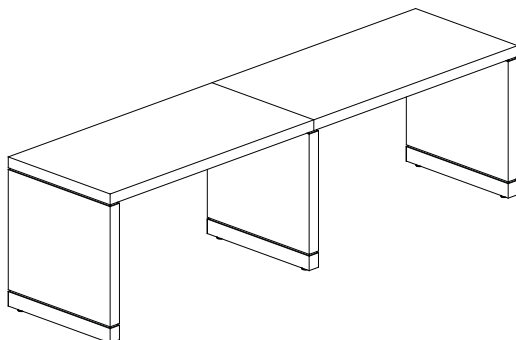

LT3B 1203042	6260	6985	120	30	42	466	15
--------------	------	------	-----	----	----	-----	----

## Lounge Tables (3" Thick) with DecoMetal Brushed Aluminum Base

Description	Product Code	HPL Price	CC Price	Dimensions			Weight	Cubic Feet
				W	D	H		

### 66" x 24" Desk Height with Power

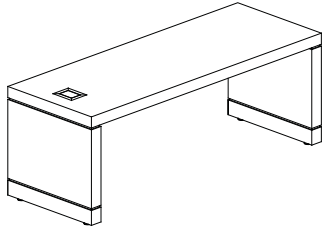

LT3B 662430 P	3895	4185	66	24	30	208	10.3
---------------	------	------	----	----	----	-----	------

### 72" x 30" Bar Height with Power

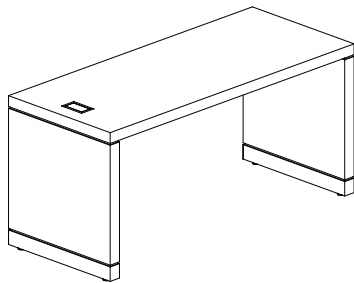

LT3B 723042 P	4360	4805	72	30	42	300	13.7
---------------	------	------	----	----	----	-----	------

### 96" x 30" Bar Height with Power

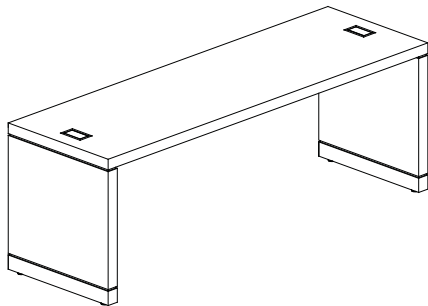

LT3B 963042 P2	5465	6045	96	30	42	364	18.2
----------------	------	------	----	----	----	-----	------

### 120" x 30" Bar Height with Power

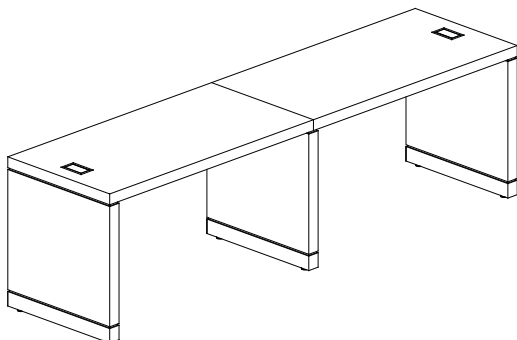

LT3B 1203042 P2	6860	7585	120	30	42	470	15
-----------------	------	------	-----	----	----	-----	----

